



IF YOU CAN *DREAM IT,*
WE CAN *DESIGN IT...!*

RAPID HOSE CLAMP AUTOMATIC FORMING MACHINE AND DECOILER

MACHINE DESIGN MASTERY THAT YOU NEED.

We offer numerous design solutions, including drills, bending, forming, cutting, fixing and rotating.



+90 212 576 7020

+90 212 576 7021

✉ export@apakgroup.com.tr

📍 Ikitelli Industrial Zone, Eskoop Ind.
Block C-1 No:36 Basaksehir, ISTANBUL, TURKEY

WWW.APAKGROUP.COM.TR

MODEL**APAK-RHC50**

Product Description

This system is a fully automatic machine designed for the production of special forms of metal clamps powered to its patented equipment.

Edge and length cutting on the system is performed by hydraulic units. With specially designed form rollers having a hardness level of 58-62 HRC, it can realize forming processes for long time without any problem.

System options include uncoiler. With the soft take-off and roll stopper, you can have uninterrupted production.

Machine has pump and liquid tank in order to provide coolant and slider liquid flow according to the product to be produced.

Working and programming with the machine is easy and user friendly

Ürün Açıklaması

Bu sistem farklı boyut ve formlara sahip boru kelepçelerinin üretimi için tasarlanmıştır. İnce rulo sacların hızlı ve kusursuz üretimi için geliştirilen dairesel büküm bölümü ile benzer sistemler ile kıyaslanamayacak hız ve son ürün kalitesine sahiptir.

Müşterilerin farklı ihtiyaçlarına göre yeniden tasarlanan büküm topları ve kesim uçları ile hasas ve temiz ürünler elde edilebilmektedir.

Sistem üzerinde bulunan rulo sac açıcı ile kesintisiz üretim yapılabilmektedir. Rulo sac açıcının yumuşak kalkış ve duruş özelliği sayesinde sarsıntısız sac açma işlemi gerçekleştirilebilmektedir.

Büküm ve kesim bölümlerinde kullanılan materyaller uzun süre hizmet verebilmesi için özel alaşım çeliklerinden üretilerek ısı işleminden geçirilmektedir.

Isıl işlem sonrasında hassas taşlama ile kusursuz bükme topları ve kesme ağızları elde edilebilmektedir.



+90 212 576 7020

+90 212 576 7021

✉ export@apakgroup.com.tr

📍 İkitelli Industrial Zone, Eskoop Ind.
Block C-1 No:36 Basaksehir, İSTANBUL, TURKEY

WWW.APAKGROUP.COM.TR

**MODEL****APAK-RHC50**

Standard Equipment

- Cooling water and oil system
- Special forming rollers
- End cutting unit
- length Cutting unit

Standart Ekipmanlar

- Soğutma suyu ve yağlama sistemi
- Özel form topları
- Kenar kesme ünitesi
- Boy kesme ünitesi

MODEL	APAK-RHC50
Cutting System	Hydraulic
MAX. Plate Thickness (mm)	0,50 mm
Net Weigh (kg)	800 kg
Power (KW)	10 KW
Voltage	380V- AC 50Hz
Pressing System	Mechanical

MODEL	APAK-RHC50
Kesme Sistemi	Hydraulic
MAX. Malzeme Kalınlığı (mm)	0,50 mm
Net Ağırlığı (kg)	800 kg
Toplam Güç (KW)	10 KW
Çalışma Voltajı	380V- AC 50Hz
Press Sistemi	Mekanik



+90 212 576 7020

+90 212 576 7021

export@apakgroup.com.tr

İkitelli Industrial Zone, Eskoop Ind.
Block C-1 No:36 Basaksehir, ISTANBUL, TURKEY

WWW.APAKGROUP.COM.TR

MODEL

APAK-RHC50



System Equipment

- 1- Emergency stop
- 2- On-Off switch
- 3- Energy lamps
- 4- LCD Screen
- 5- Adjustment bolts
- 6- Hydraulic cutting piston
- 7- Edge cutting mold
- 8- 9 Pcs of form rolls
- 9- Water line
- 10- Length cutting hydraulic piston
- 11- Length cutting mold
- 12- Sheet opener switch
- 13- De-coiling unit
- 14- Steel sheet
- 15- Sheet holder screw

Sistem Ekipmanları

- 1- Acil Stop
- 2- Açma kapama şalter
- 3- Enerji lambası
- 4- LCD Ekran
- 5- Ayar civataları
- 6- Hidrolik kesme pistonu
- 7- Kenar kesme kalıbı
- 8- 9 adet form kalıbı
- 9- Kolon kaldırma redüktörü
- 10- Boy kesme hidrolik pistonu
- 11- Boy kesme kalıbı
- 12- Sac açıcı kumanda panosu
- 13- Rulo sac açma makinesi
- 14- Rulo Sac
- 15- Rulo sac sıkma vidası



MODEL

APAK-RHC50

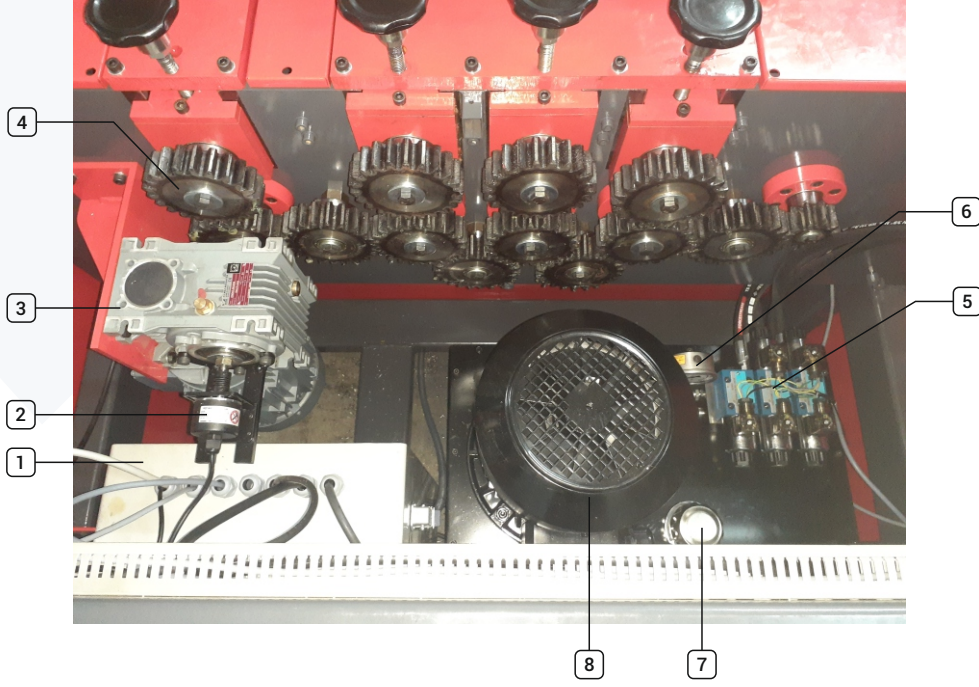

System Equipment

- 1- Control panel
- 2- Encoder
- 3- Engine and gearbox
- 4- Gears
- 5- Hydraulic valves
- 6- Hydraulic oil pressure gauge
- 7- Hydraulic oil tank cap
- 8- Hydraulic motor

Sistem Ekipmanları

- 1- Kontrol Panosu
- 2- Encoder
- 3- Motor ve şanzuman
- 4- Dişli grubu
- 5- Hidrolik valfler
- 6- Hidrolik basınç göstergesi
- 7- Hidrolik ünite yağ kapağı
- 8- Hidrolik ünite motoru



+90 212 576 7020

+90 212 576 7021

export@apakgroup.com.tr

İkitelli Industrial Zone, Eskoop Ind.
Block C-1 No:36 Basakşehir, İSTANBUL, TURKEY

WWW.APAKGROUP.COM.TR

MODEL

APAK-RHC50



Water pan and circulation pump / Su ünitesi



SPECIAL ROLL FORM MOLDS

The bending roll shape are determined by customers' products and powered for hardening with heat treatment processing according to the product specification.

After heat treatment and hardening progress, rolls transferring to surface grinding process.

Forming rolls are made for various size and numbers as sets based on customers need.



DE-COILER SYSTEM

Steel sheet feeder take part in the machine system.

It has a smooth starting and stopping feature, also equipped to a straight and impact-free sheet sliding feature.

Practical loading can be done with a single center clamping feature.

The capacity of de-coilers are designed and produced to meet the needs of the customer.



+90 212 576 7020

+90 212 576 7021

✉ export@apakgroup.com.tr

📍 Ikitelli Industrial Zone, Eskoop Ind.
Block C-1 No:36 Basaksehir, ISTANBUL, TURKEY

WWW.APAKGROUP.COM.TR

MODEL

APAK-RHC50

**RAPID HOSE CLAMP FORMING MACHINE
KELEPÇE FORM MAKİNESİ**

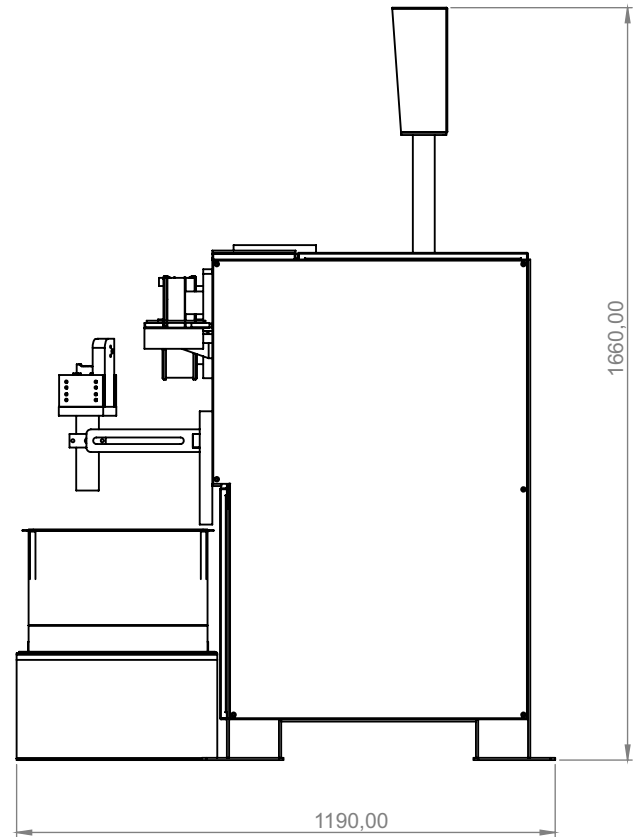
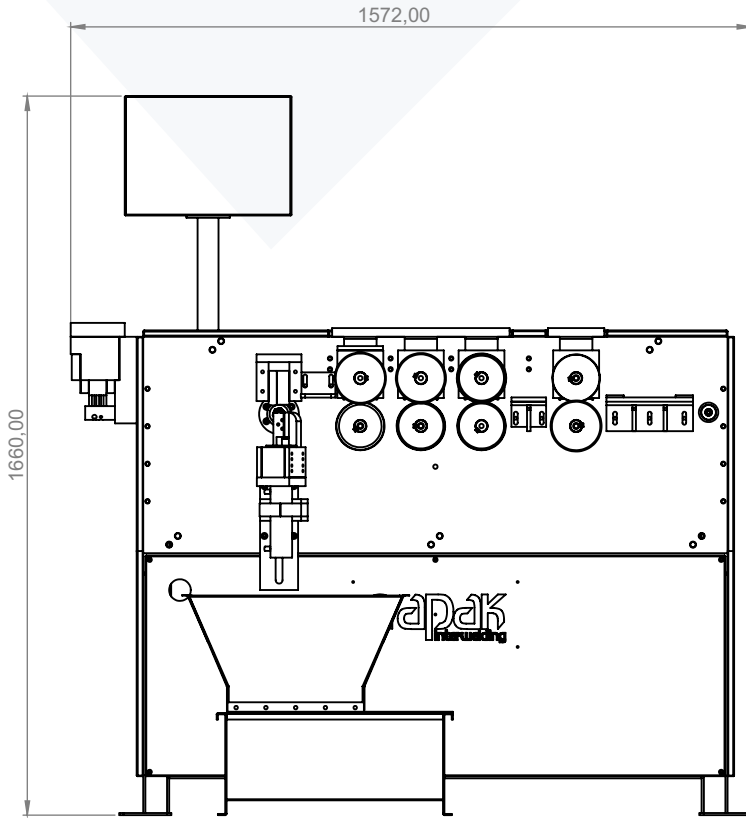

DECOILER / RULO SAC AÇICI

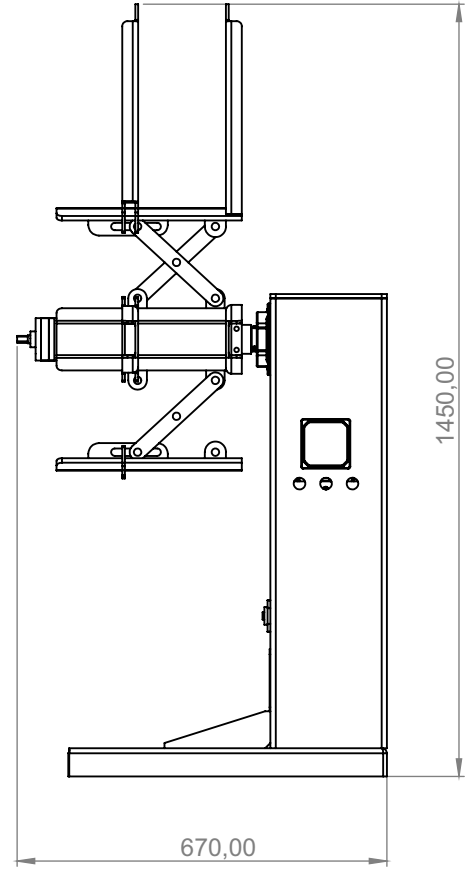
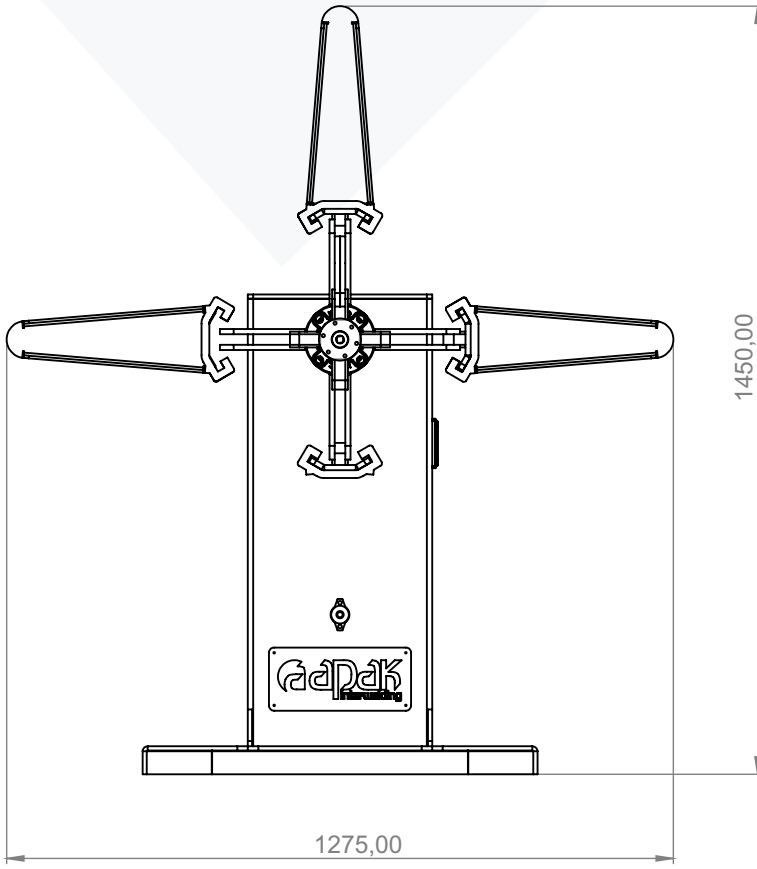

ABOUT APAK GROUP COMPANIES

Since 1972 Apak Group has proudly served the steel construction, plate fabrication, and metal working industries with the most innovative equipment on the market located in Malatya (Turkey). In 2010 we opened a new workshop in Istanbul to develop international and global marketing. We are the solution of Welding, Bending and Cutting of steel industry, For this, we are working continually on progress and developing for our customers technologies which are easy to use, sustainable and specifically tailored to the respective requirements.

APAK GRUP HAKKINDA

APAK GROUP 1972 den bu güne Malatya'da en yenilikçi ekipmanlarla çelik konstrüksiyon, levha imalatı ve metal işleme endüstrilerine gururla hizmet vermiştir. 2010 yılında uluslar arası ve küresel pazarlamayı geliştirmek için İstanbul'da yeni bir imalathane açmıştır. Çelik endüstrisinin Kaynak, Bükme ve kesme çözümleri ile sektörel otomasyon sistemleri tasarlamaya ve üretmeye devam etmiştir. Kullanımı kolay, sürdürülebilir ve özel olarak gereksinimlere göre geliştirilmiştir, müşterilerimizin teknolojik yatırımları gerçekleştirmesi ve kolay ulaşması için çalışıyor ve kendimizi her geçen gün geliştiriyoruz.

